



OEM Quarterly News

In this issue:

- 1 OEM News
- 1 Intermec News
- 2 Andy's Tips
- 2 Meet the Partner – Hi Pro Solutions
- 2 OEM Sales Team Members



Intermec News

Intermec finished 2008 on a high note in spite of a very chaotic economy though the second half of the year. Intermec posted 2008 revenues of \$891M USD which is a year over year growth of 5%. Intermec also finished the year with an exceptionally strong balance sheet. With over \$200M in cash and cash equivalents the company is well positioned to continue investment in R&D and weather the current economic storms. I think it's important to consider this fact as you weight options on scan engine suppliers over the course of 2009. You definitely want to make sure that your supplier is not only financially healthy but that the OEM division of the company is well positioned and a strategic part of the overall business. Please see our complete annual results at www.intermec.com. Stop by for a visit, we would love to have you.

OEM News

by Warren Rainer, OEM Sales Director, *email*

Welcome to our Q1 newsletter and to the New Year. Thanks so much for all your support and trust in us in 2008, we greatly appreciate your business. On the horizon 2009 appears to be a year that will present a lot of challenges to all of us in the business world. I hope that your business is still finding good opportunities to not only weather the current economic climate but to continue to build for the future. Here at Intermec we are being watchful of the economy as well as bullish about the opportunities in data collection. To that end we are extremely excited to announce a new member to the growing family of Intermec scan engines, the EA25X. Intermec's dedicated scan engine research and design center in Toulouse, France has been hard at work developing this breakthrough device. The EA25X will provide you with the kind of competitive advantage that can help distinguish your products from the crowd. While it's no secret that 2D imaging is quickly leaving it's mark on the market share numbers in AIDC it is also true that the majority of the market is still a 1D world. One of the reasons for this is that traditional 2D scan engines lacked the depth of field that has been a hallmark of the 1D engine. Early on this depth of field advantage was the province of the laser scan engine. In recent years however technology breakthroughs by Intermec and others have put 1D imagers into the same class of performance as their laser counterparts.



In spite of the depth of field and cost advantages of 1D, the 2D engine has continued its rapid growth and invasion into the 1D market. The many advantages of 2D simply outweigh the limited advantages of the 1D. That said it would, of course, be outstanding if you could provide your customers with a 2D engine that has the kind of range performance that customers enjoy from their legacy 1D products. Well, thanks to David Downey and his team in Toulouse, you can have your cake and eat it too! That's right, the EA25X provides all the features you expect in a 2D scan engine as well as the type of scan range you expect from a 1D. Thanks to the superior engineering work from David's team, Intermec is able to combine the read range of a 1D scan engine with the features of a 2D. A superior combination of optical, mechanical, electrical and software design have resulted in the EA25X from Intermec. Not only have the Toulouse Engineers stretched the limits of 2D scanning they have done it within the interface standards of the existing Intermec family. As with other Intermec engines the EA25X is electrically plug compatible with the widely popular EA15, EV15 and EV12 scan engines from Intermec. Additionally the firmware is all compatible with Intermec's ISCP scan engine control language. Your concern about which technology or engine to choose becomes a lot easier because you can flex with the market demand while being able to use only limited engineering to go from one engine integration to the next. The EA25X is available today in developer kits and samples for you to test and see for yourself. Please contact you local OEM sales rep for more information and the chance to order up a sample, I am confident you will be impressed.



Andy's Tips

by Andy Reynolds, Global Systems Consultant, [email](#)

As Warren has introduced the EA25X engine to you, I want to review the key integration consideration. To get the extended read range performance from the EA25X, the EA25X has a different optics engine or EA20X. This replaces our standard 2D imager engine, EA11, and is pin compatible. Key to a quick

integration of this engine into your existing 2D product was to make sure the engine optics mounted in the same location as that of the EA11 and to have enough room. The overall depth of the EA20X is 2.5 mm greater than EA11 (16.5 mm versus 14 mm).

EA20X

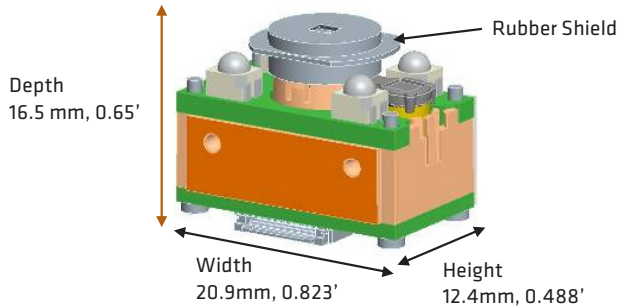

In addition, the mounting holes need to be placed in same location relative to the front face of the engine. EA11 is mounted 8.7 mm and EA20X is at 9 mm. We kept these very close to the same so the reflections off of windows, placed in front of the engine, to a minimum. This provides the best performance and eases integration so only the greater depth of the engine is the main consideration. The mounting hole change does force us only offer a 2 piece solution of the EA25X (EA20X with our decode board).

EA11

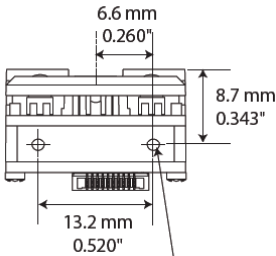

EA20X

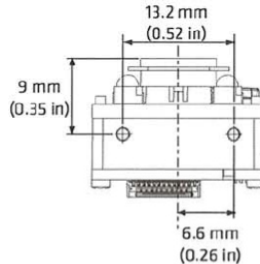

We have also added the rubber shield to decrease reflection off of the laser aiming system, improve ambient light sensitivity and to cushion the engine from any window distortion during an impact. We hope you experience the greater range of the EA25X soon. As always we are here to assist you with your integration needs, so please do not hesitate to let us know how we can help.

OEM Sales Team



Mark Timms
Account Manager –
America's
[email](#)



Takaharu Moridaira
Account Manager –
APAC
[email](#)



Cédric Mollon
Account Manager –
EMEA
[email](#)



Joyce Yu
Account Manager –
Taiwan
[email](#)



Ken Mott
Systems Engineer
[email](#)



Monica Chandler
Customer Support
Specialist
[email](#)



Meet the Partner

Intermec utilizes select partners to help provide fulfillment of the sale of our engines into specific markets, specialty applications and smaller volume requirements. One such partner is Hi Pro Solutions, located in Italy. Hi Pro Solutions projects and develops solutions for the Supply Chain cycle, based on Auto-ID technologies through Barcode, RFID, Voice, in batch and wireless environments, contributing to an efficient and effective production process and bringing innovation on the whole process cycle: Production Data, Warehouse, Deliveries. Hi Pro Solutions acts in three focusing and complementary areas: Data Collection: Auto-ID solutions; Security: access control, biometric technologies and Work Force Automation: sales force automation, maintenance and in-field automation projects. All the group activities are supported by qualified services of pre/post sales, technical assistance and project consulting. Check them out at <http://www.hipro.it/>.